



SX7

Seven Axle Side Dump Trailer

THE FIRST
Seven-Axle
SIDE DUMP



Hauls 40 tons ◀ 40-foot tub ◀ Standard CDL ◀ Tight turns

800-779-8099 • 712-546-4409 • sidedump.com

Seven Axle Side Dump
SX7



SX7

Seven Axle Side Dump Trailer

Model SX7 SmithCo Side Dump Trailer

Specs shown are for 53' frame length; other configurations available.

Frame Length	53'
Tub Length	40'
Width	102"
Height	8' 7" at Tub side, 9' 7" at Center
Tub Construction	1/4" Thick, AR400 Steel (or equivalent) 3/16" Thick, AR400 Steel (or equivalent) is optional External Column Supports, No Center Tub Divider
Frame Construction	80/100 KSI, Fabricated Steel I-Beam
Kingpin	2" Kingpin, 16" Setting, Replaceable Type
Landing Gear	Two Speed, Load Bearing
Bumper	Push Bar Type, Bolt-On
Cylinders	3500 PSI, 6" bore
Hinges	Self-Aligning, Spherical Bearing Type (greaseable)
Suspension	Air Ride Suspension Standard
Axles	(3) 25,000# capacity (4) 13.2K Air Ride/Lift/Steerable
Hubs	10 Hole, Hub Piloted
ABS	2S1M Anti-Lock Brake System
Drums	Outboard Mount, Cast Steel
Wheels	Steel Disc, 8.25 X 22.5 (12), 9 X 22.5 on Steerable/lift (8)
Tires	11 R 22.5 G Radial Tires on Mains 295/75 R 22.5 on Steerable/lift
Brakes	16 1/2" x 7" std, Disc Brakes available
Fenders	Front & Rear, 1/4" Synthetic, 7 Degree Slope
Lights	12 Volt LED, ICC w/ Sealed Harness
Mud Flap	(4) Polyline Anti-Spray Splash Guard w/SmithCo name
Paint	Polyurethane, any combination of gray, white or black Special colors available upon request

SX7 Series Tub Capacities

	40' Tub
Waterfull	26.8 cu yd
Heaped	35.6 cu yd

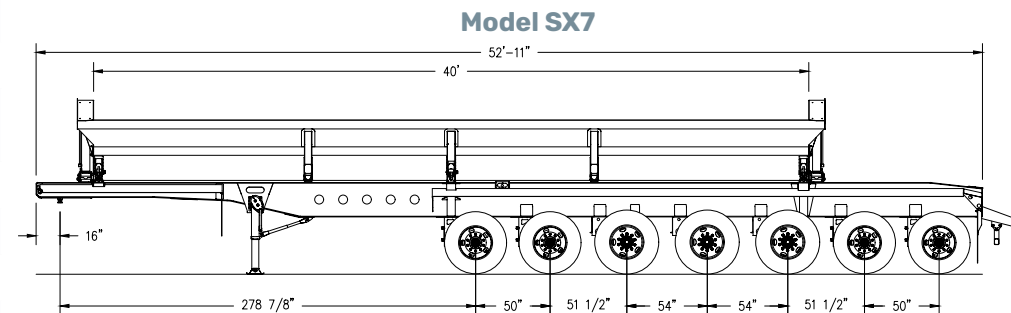
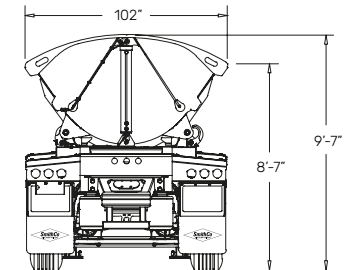

Min. Tractor Hydraulic Reqs.

25-30 GPM, 3000 PSI, 10 Gallon Reservoir