

# DUMP TRAILER



14,000 GVW • 16,000 GVW • 20,000 GVW



Optional step



83" Between Fenders • 3/16 Floor • (6) D-rings, Inside Box  
Champion Scissors Lift • 11-Ton Lift Capacity • 12' to 18' Lengths

**BT** **BEHNKE**  
TRAILERS SINCE 1987



(563)744-3246

[www.behnkeenterprises.com](http://www.behnkeenterprises.com)

# DUMP TRAILER

14,000 GVW  
16,000 GVW  
20,000 GVW

14,000 GVW			
	Side Height	Side Height	
Bed Length	2'	3'	Axle Size
12'	LPD83X12E702		(2) 7K AXLE
12'		LPD83X12E703	(2) 7K AXLE
14'	LPD83X14E702		(2) 7K AXLE
14'		LPD83X14E703	(2) 7K AXLE
16'	LPD83X16E702		(2) 7K AXLE
16'		LPD83X16E703	(2) 7K AXLE

16,000 GVW			
	Side Height	Side Height	
Bed Length	2'	3'	Axle Size
12'	LPD83X12E802		(2) 8K AXLE
12'		LPD83X12E803	(2) 8K AXLE
14'	LPD83X14E802		(2) 8K AXLE
14'		LPD83X14E803	(2) 8K AXLE
16'	LPD83X16E802		(2) 8K AXLE
16'		LPD83X16E803	(2) 8K AXLE

20,000 GVW			
	Side Height	Side Height	
Bed Length	2'	3'	Axle Size
14'	LPD83X14E102		(2) 10K AXLE
14'		LPD83X14E103	(2) 10K AXLE
16'	LPD83X16E102		(2) 10K AXLE
16'		LPD83X16E103	(2) 10K AXLE
18'	LPD83X18E102		(2) 10K AXLE
18'		LPD83X18E103	(2) 10K AXLE

## Approximate Weights

LPD83X14E702	4,860 lb.
LPD83X14E703	4,950 lb.
LPD83X16E702	6,075 lb.
LPD83X16E703	6,280 lb.
LPD83X14E802	5,780 lb.
LPD83X14E803	5,925 lb.
LPD83X16E802	6,080 lb.
LPD83X16E803	6,520 lb.
LPD83X14E102	7,160 lb.
LPD83X14E103	7,300 lb.
LPD83X16E102	7,260 lb.
LPD83X16E103	7,470 lb.
LPD83X18E102	8,200 lb.
LPD83X18E103	8,260 lb.

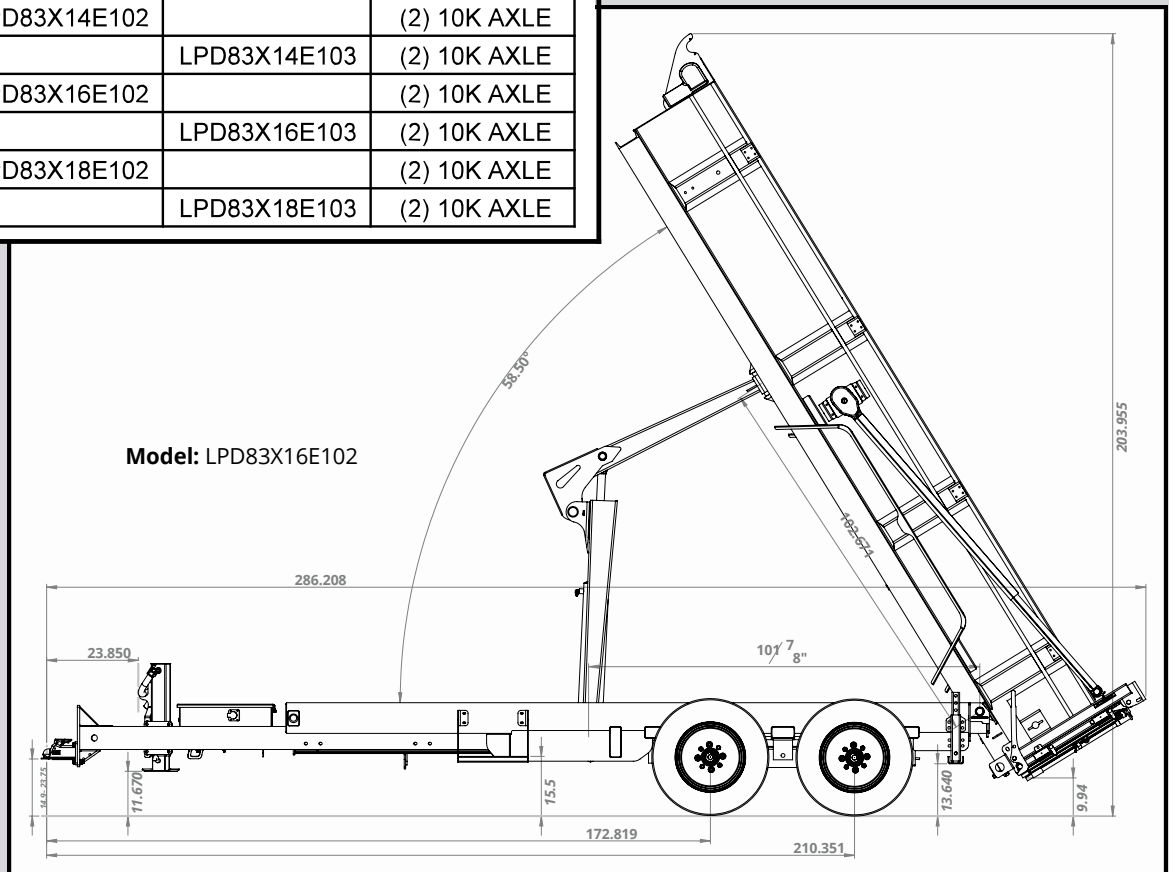

**BEHNKE** BT  
TRAILERS SINCE 1977



Behnke Enterprises, Inc.  
800 Ninth Ave. NW • Farley, IA 52046

www.behnkeenterprises.com • (563) 744-3246